

## SFP-CL32TG-10Dx

### 10.3Gb/s CSFP+ BIDI Transceiver

#### Product Features

- Two Bi-Directional transceivers in one SFP package
- Up to 10.3Gb/s data links
- Duplex LC connector
- Hot-pluggable SFP footprint
- 1310nm DFB laser transmitter
- RoHS compliant and Lead Free
- Up to 10Km on 9/125um SMF
- Metal enclosure for lower EMI
- Single +3.3V power supply
- Compliant with CSFP MSA 2.0 (Option 2)
- Commercial and industrial operating temperature optional
- SFP MSA SFF-8074i Compliant
- Operating case temperature:  
Standard: 0 to +70°C  
Industrial: -40 to +85°C



#### Applications

- 10Gbps Optical systems
- 10GBASE-LR at 10.3125Gbps
- 10GBASE-LW at 9.953Gbps

#### Regulatory Compliance

- ESD to the Electrical PINs: compatible with MIL-STD-883 Method 3015
- ESD to the Single LC Receptacle: compatible with IEC 61000-4-2
- Immunity compatible with IEC 61000-4-3
- EMI compatible with FCC Part 15 Class B EN55022 Class B (CISPR 22B) VCCI Class B
- Laser Eye Safety compatible with FDA 21CFR 1040.10 and 1040.11 EN60950, EN (IEC) 60825-1,2
- RoHS compliant with RoHS 2 (2011/65/EU)

## Absolute Maximum Ratings

Parameter	Symbol	Min	Max	Unit
Supply Voltage	V <sub>cc</sub>	-0.5	4	V
Storage Temperature	T <sub>s</sub>	-40	+85	°C
Operating Humidity	-	5	85	%

## Recommended Operating Conditions

Parameter	Symbol	Min	Typical	Max	Unit
Operating Case Temperature	Standard	0		+70	°C
	Industrial	-40		+85	°C
Power Supply Voltage	V <sub>cc</sub>	3.13	3.30	3.47	V
Power Supply Current	I <sub>cc</sub>			700	mA
Data Rate			10.3		Gbps
9/125um G.652 SMF	L <sub>max</sub>			10	km

## Optical and Electrical Characteristics

Parameter	Symbol	Min	Typical	Max	Unit	Notes
<b>Transmitter</b>						
Centre Wavelength	$\lambda_c$	1320	1330	1340	nm	
Spectral Width (RMS)	$\Delta\lambda$	-	-	1	nm	
Side-Mode Suppression Ratio	SMSR	30	-	-	dB	
Average Output Power	P <sub>out</sub>	-5		2	dBm	1
Extinction Ratio	ER	3.5	-	-	dB	
Data Input Swing Differential	V <sub>IN</sub>	180		850	mV	2
Input Differential Impedance	Z <sub>IN</sub>	90	100	110	$\Omega$	
TX Disable	Disable	2.0		V <sub>cc</sub>	V	
	Enable	0		0.8	V	
TX Fault	Fault	2.0		V <sub>cc</sub>	V	
	Normal	0		0.8	V	

Receiver						
Centre Wavelength	$\lambda_c$	1260	1270	1280	nm	
Receiver Sensitivity		-	-	-12	dBm	3
Receiver Overload		0.5	-	-	dBm	3
LOS De-Assert	LOS <sub>D</sub>			-14	dBm	
LOS Assert	LOS <sub>A</sub>	-30			dBm	
LOS Hysteresis	-	0.5	-	5	dB	
Data Output Swing Differential	V <sub>out</sub>	300		900	mV	4
LOS	High	2.0		V <sub>cc</sub>	V	
	Low			0.8	V	

**Notes:**

1. The optical power is launched into SMF.
2. PECL input, internally AC-coupled and terminated.
3. Measured with a PRBS 2<sup>31</sup>-1 test pattern @10.3Gbps, BER ≤1×10<sup>-12</sup>.
4. Internally AC-coupled.

**Diagnostics**

Parameter	Range	Unit	Accuracy	Calibration
Temperature	0 to +70	°C	±3°C	Internal
	-40 to +85			
Voltage	3.0 to 3.6	V	±3%	Internal
Bias Current	0 to 100	mA	±10%	Internal
TX Power	-5 to 2	dBm	±3dB	Internal
RX Power	-12 to 0.5	dBm	±3dB	Internal

**EEPROM Information**

Memory map for 2ch Compact SFP (option 2) is illustrated in below figure. A0h (1010000X) and B0h (1011000X) are the Serial ID addresses for channel 1 and channel 2, respectively A2h (1010001X) and B2h (1011001X) are the Digital Diagnostic addresses for channel 1 and channel 2.

Channel 1: 2 wire address 1010000X (A0h)  
Channel 2: 2 wire address 1011000X (B0h)

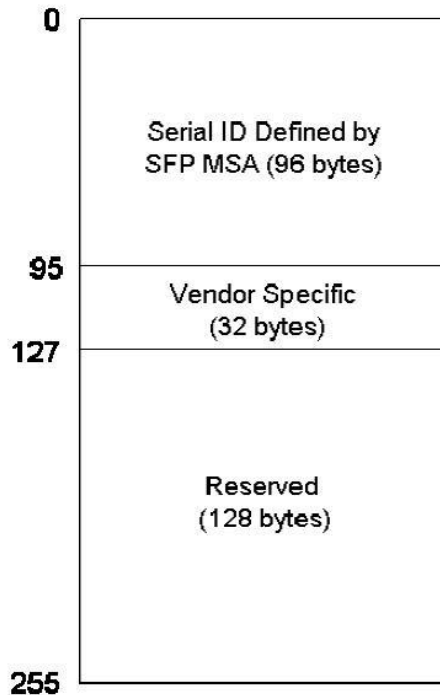

Channel 1: 2 wire address 1010001X (A2h)  
Channel 2: 2 wire address 1011001X (B2h)

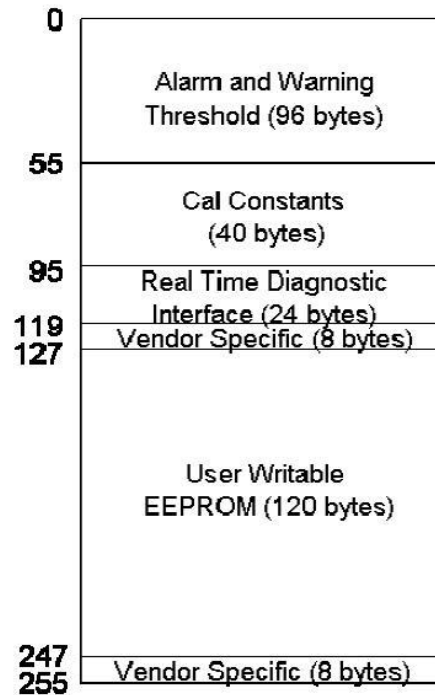

## Pin Descriptions

Pin	Signal Name	Description	Plug Seq.	Notes
1	VeeT	Transmitter Ground (Common with Receiver Ground)		
2	TX Fault	Transmitter Fault.		
3	TX1_Disable	Transmitter Disable of Ch1; Turns off transmitter laser output of Ch1.		
4	MOD_DEF(2)	2-wire Serial Interface Data Line (SDA).		
5	MOD_DEF(1)	2-wire Serial Interface Clock Line (SCL).		
6	TD2-	Inverted Transmit Data Input of Ch2.		
7	TD2+	Transmit Data Input of Ch2.		
8	LOS1	Loss of signal for Ch1.		
9	RD2+	Received Data Output of Ch2.		
10	RD2-	Inverted Received Data Output of Ch2.		
11	VeeT	Transmitter Ground.		
12	RD1-	Inverted Received Data Output of Ch1.		

13	RD1+	Received Data Output of Ch1.		
14	LOS2	Loss of signal for Ch2.		
15	VccR	Receiver Power Supply.		
16	VccT	Transmitter Power Supply.		
17	Tx2_Disable	Transmitter Disable of Ch2; Turns off transmitter laser output of Ch2.		
18	TD1+	Transmit Data Input of Ch1.		
19	TD1-	Inverted Transmit Data Input of Ch1.		
20	VeeT	Transmitter Ground		

**Notes:**

TX\_ Fault is internally OR output for TX fault conditions in either Channel 1 or Channel 2. In order to determine which channel is at fault, the Host can read the internal memory bits for.

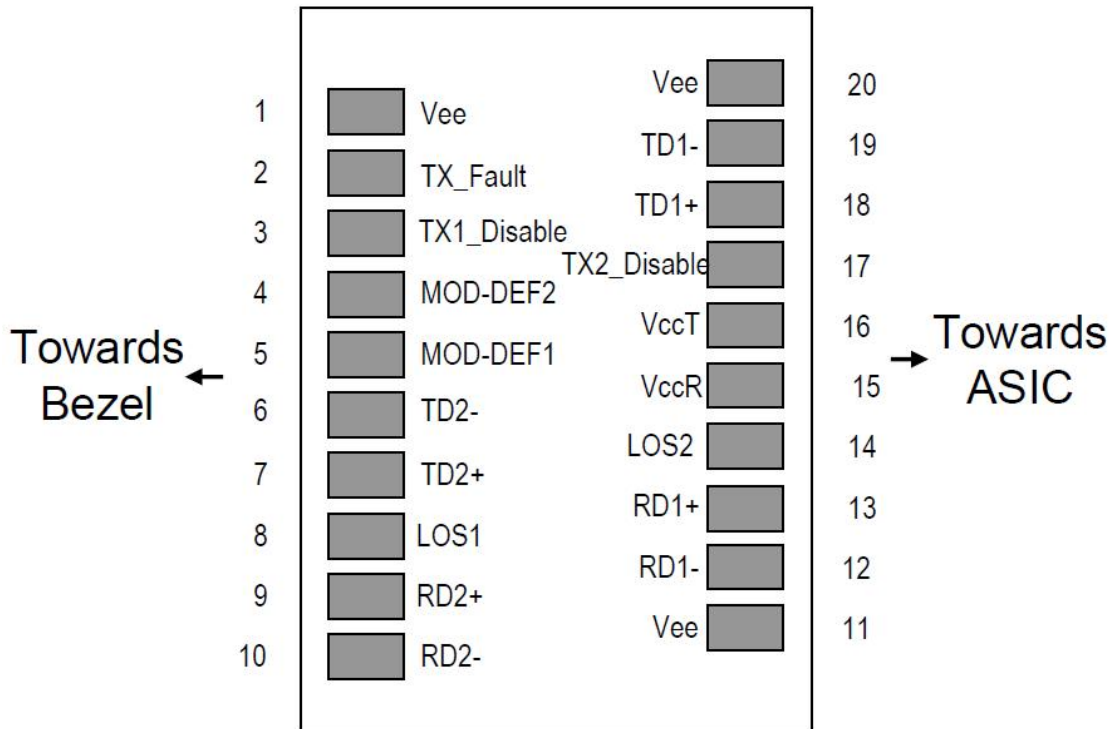

**Pin-out of Connector Block on Host Board**

## Recommended Interface Circuit

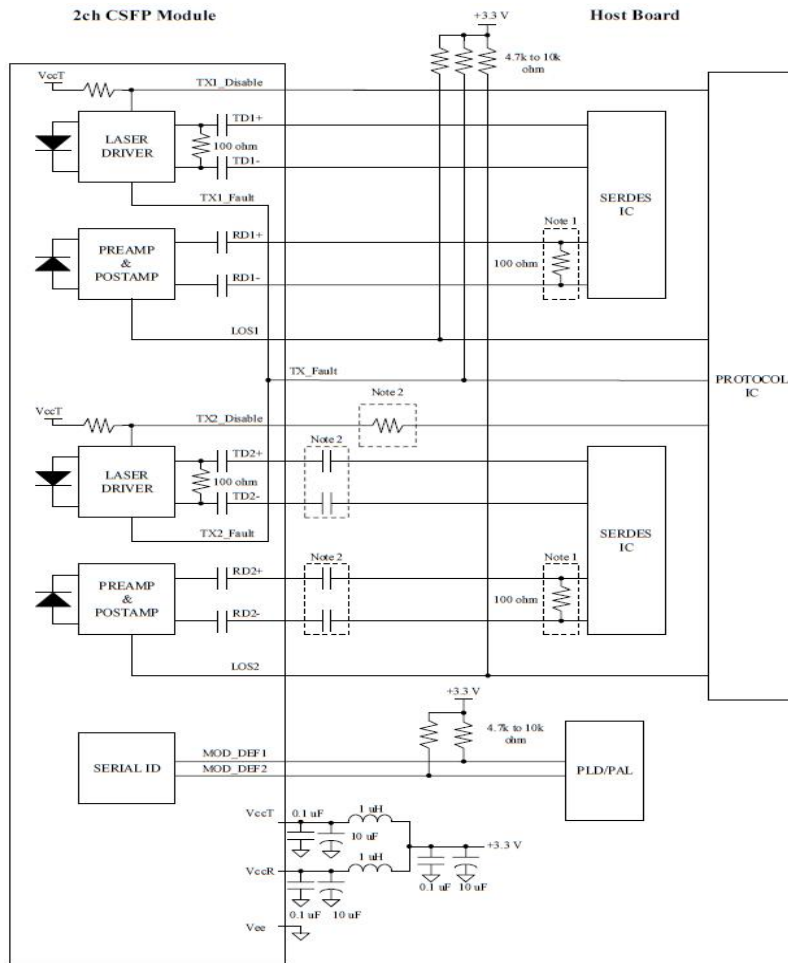

## Mechanical Dimensions

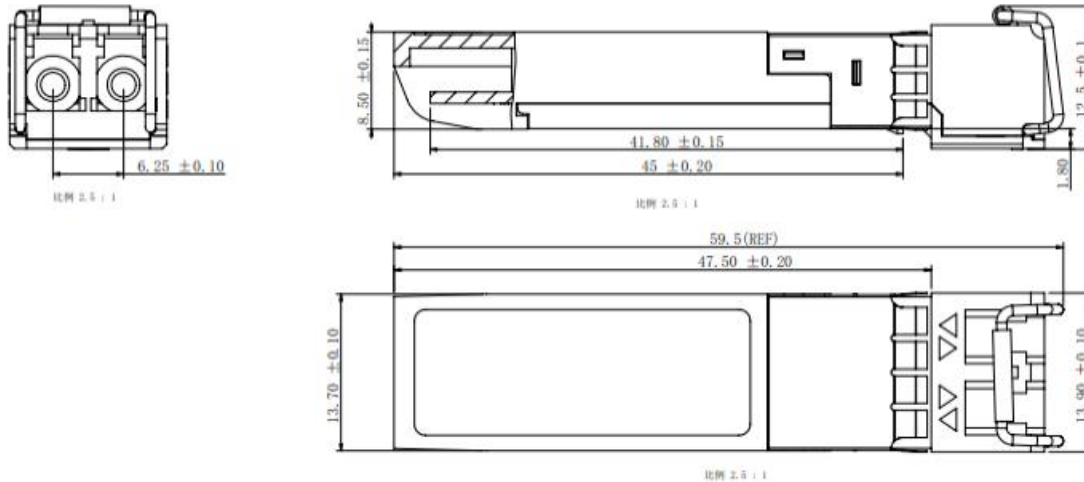

## Ordering information

Part Number	Product Description
SFP-CL32TG-10DC	1330T/1270R 10.3Gbps LC 10km 0°C~+70°C with DDM
SFP-CL32TG-10DI	1330T/1270R 10.3Gbps LC 10km -40°C~+85°C with DDM

## For More Information

Tel: +86-755-23301665

E-mail : [sales@fibertoptech.com](mailto:sales@fibertoptech.com)

Web: <http://www.fibertoptech.com>